

01-75 SERIES
01-75M SERIES

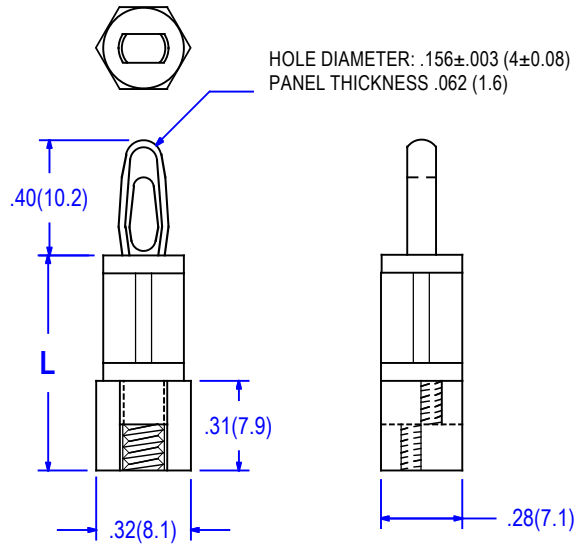

M 4 THREAD ITEM NO.	6-32 THREAD ITEM NO.	L	
		In. ±.015	mm. ± 0.4
01-75M4- 60	01-75- 60	.375	9.5
01-75M4- 80	01-75- 80	.500	12.7
01-75M4-100	01-75-100	.625	15.9
01-75M4-120	01-75-120	.750	19.1
01-75M4-140	01-75-140	.875	22.2
01-75M4-160	01-75-160	1.00	25.4

PACKAGING : 1000 PER BAG

UL 94V-O MATERIAL AVAILABLE UPON REQUEST
TO ORDER ADD SUFFIX "X" TO ITEM NUMBER

MATERIAL	NYLON 66
UL RATING	94V-2
UL FILE NO.	E41938
COLOR	NATURAL
RoHS COMPLIANCE	YES
TEMPERATURE RANGE (REF.)	-40 to185°F (-40 to 85°C)
MR NUMBER	12

					BY	DATE	Title CIRCUIT BOARD SUPPORT, THREADED.	
					CUSTOMER APPROVAL			
					VERIFIED			
					REVIEWED	DP	.12-16-15	Part No.
					DRAWN	FL	12-14-15	See table
					DIMENSIONS Inches mm Tolerance .xx = ± .010 .xxx = .005			Issue
					ALL ELECTRONICS HARDWARE INC. 2642 Corporate Parkway Algonquin, IL. 60102 1-800-778-7234			Drwg. type CATALOG
No	Revision	Date	Init.		File No.	01-75series		12-14-15 O 12-14-15